



Mercedes College

Year 12

TRIAL WACE Examination 2016

ATAR PHYSICS 12 – Unit 3 & 4

Write your name here

Time allowed for this paper

Reading time before commencing work: ten minutes
Working time for paper: three hours (180 minutes)

Materials required/recommended for this paper

To be provided by the supervisor

This Question/Answer Booklet
Formulae and Constants Sheet

To be provided by the candidate

Standard items: pens, pencils, eraser, correction fluid, ruler, highlighters

Special items: non-programmable calculators satisfying the conditions set by SCASA for this course.
Graphics calculators may **not** be used.

Important note to candidates

No other items may be taken into the examination room. It is **your** responsibility to ensure that you do not have any unauthorised notes or other items of a non-personal nature in the examination room. If you have any unauthorised material with you, hand it to the supervisor **before** reading any further.

MARKS SUMMARY

Section A (60 marks = 30%)	Section B (100 marks = 50%)	Section C (40 marks = 20%)	Total Mark (200)	Final %

Structure of this paper

Section	Number of questions available	Number of questions to be answered	Suggested working time (minutes)	Marks available	Percentage of exam
Section A: Short answers	14	4	55	60	30
Section B: Extended Answer	8	8	85	100	50
Section C: Comprehension and Data Analysis	2	2	40	40	20
					100

Instructions to candidates

1. The rules for the conduct of Western Australian external examinations are detailed in the *Year 12 Information Handbook 2016*. Sitting this examination implies that you agree to abide by these rules.
2. Write your answers in this Question/Answer Booklet. Use **blue** or **black** biro.
3. Working or reasoning should be clearly shown when calculating or estimating answers. In calculations, give final answer to three significant figures and include appropriate units where applicable.

In estimates, give final answers to a maximum of two significant figures and include appropriate units where applicable.
4. You must be careful to confine your responses to the specific questions asked and to follow any instructions that are specific to a particular question.
5. The "Formula and Constants Sheet" may be used as required.

SECTION A: (Short Answer questions - 60 marks or 30 % of total for paper)

Answer all 14 questions in the spaces provided.

Question 1

A stone block is pulled at a constant speed up an incline by a cable attached to an electric motor.

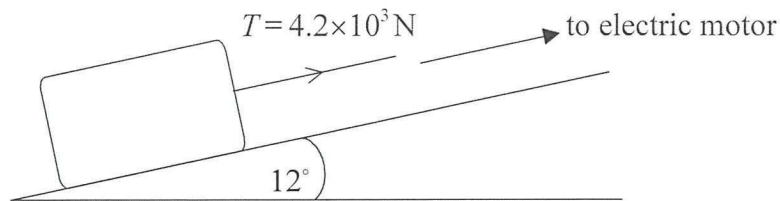

The incline makes an angle of 12° with the horizontal. The weight of the block is $1.5 \times 10^4 \text{ N}$ and the tension T in the cable is $4.2 \times 10^3 \text{ N}$.

Calculate the magnitude of the friction force acting on the block.

[3 marks]

Question 2

A car wheel is held in place by four nuts. Each nut was put on by a machine that tightened it with a torque of $3.00 \times 10^2 \text{ Nm}$.

The photograph below shows the 30.0 cm long horizontal lever that is used to remove the nuts from the wheel.



Assuming that it also takes $3.00 \times 10^2 \text{ Nm}$ to undo the nut, show (by calculation) that if a person of mass 90.0 kg stands on the end of the lever without bouncing, the weight of the person is **not** enough to turn the wheel nut.

[3 marks]

SEE NEXT PAGE

Question 3

The diagram below shows a magnet with pole pieces that are each 40 cm x 10 cm.

The uniform magnetic field strength between the poles is $1.95 \times 10^{-3} \text{ T}$, and zero outside the poles. A conducting wire, AB, carrying a current of 3.85 A, is placed between the poles as shown.

The force on the wire is upwards.

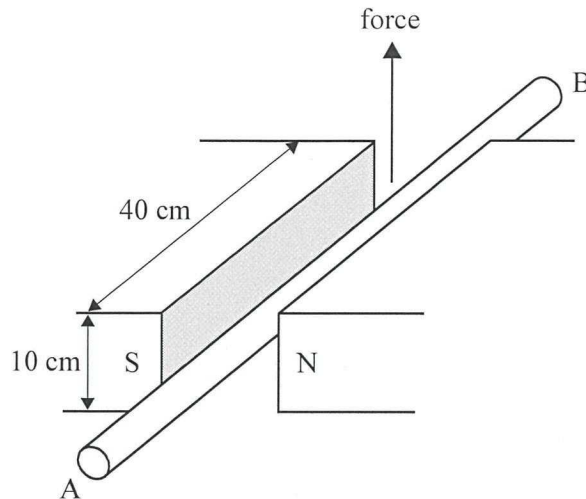

- a) In which direction, **A to B** or **B to A**, is the current flowing in the wire?

[1 mark]

- b) What is the magnitude of the force acting on the wire?

[2 marks]

SEE NEXT PAGE

Question 4

The diagram below shows the path of a charged particle that has entered a magnetic field of magnitude $B = 0.14 \text{ T}$, which is directed into the page. The initial velocity of the particle was $4.25 \times 10^5 \text{ ms}^{-1}$, perpendicular to the magnetic field. The particle has a charge of magnitude $3.2 \times 10^{-19} \text{ C}$.

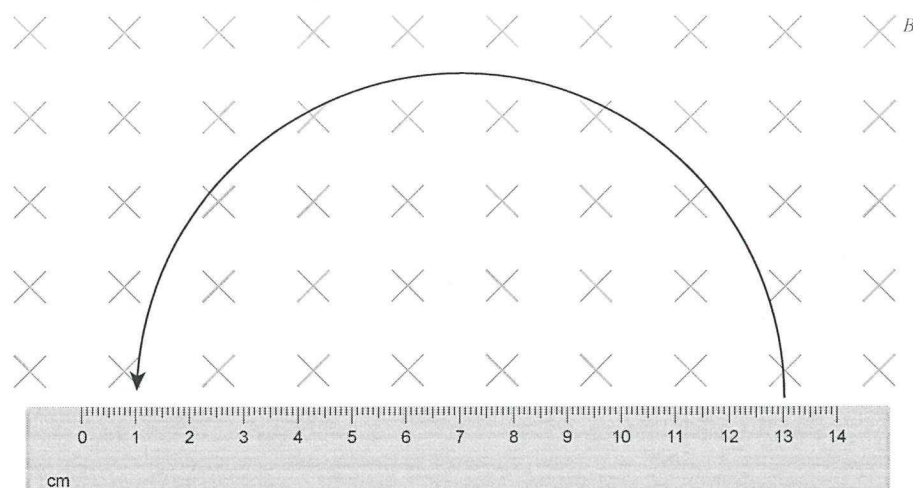

Using the above diagram determine:

- a) the sign of the charge of the particle. _____

[1 mark]

- b) the mass of the charged particle.

[2 marks]

SEE NEXT PAGE

Question 5

Natasha is shooting at goal in a game of basketball. She stands 3.0 m from the hoop. She throws a ball with an initial velocity of 6.5 ms^{-1} at an angle of 60° above the horizontal. The hoop is 1.35 m above the bottom of the ball when it is released.

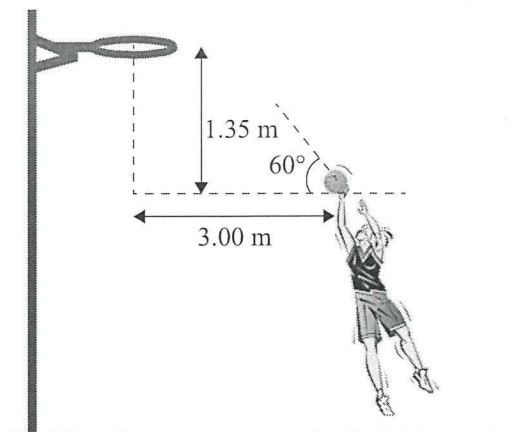

With appropriate calculations, determine whether or not the ball will go through the hoop. Begin your answer by calculating the horizontal and vertical components of the ball's initial velocity.

[5 marks]

SEE NEXT PAGE

Question 6

A vertical metal rod of length 0.25 m moves in a horizontal circle about a vertical axis in a uniform horizontal magnetic field.

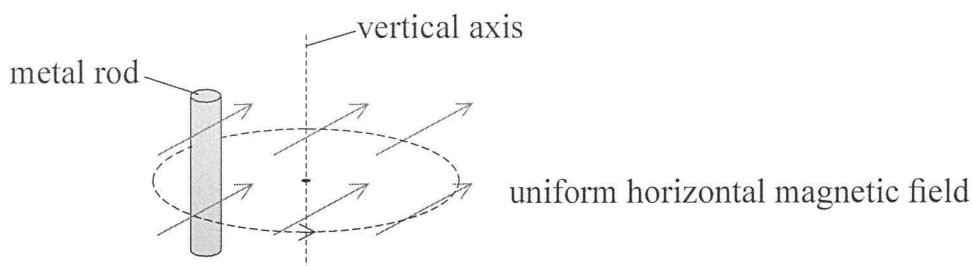

The metal rod completes one circle of radius 0.066 m in 0.020 seconds in the magnetic field of strength 61 mT

- a) Determine the maximum EMF induced between the ends of the metal rod.

[3 marks]

- b) Using the axes, sketch a graph to show the variation with time of the induced EMF in the metal rod.

[2 marks]

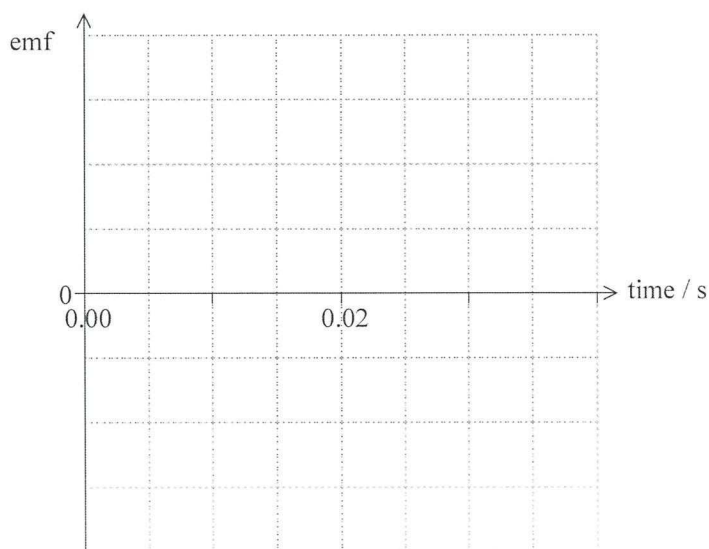

Question 7

This question is about special relativity, simultaneity and length contraction.

One of the postulates of special relativity may be stated as”

“The laws of physics are the same for all observers in inertial frames of reference”

a) What is meant by an inertial frame of reference?

[1 mark]

b) State the other postulate of special relativity.

[1 mark]

A spaceship is travelling to the right at a speed of $0.75c$, through a tunnel which is open at both ends. Observer **A** is standing at the centre of one side of the tunnel. Observer **A**, for whom the tunnel is at rest, measures the length of the tunnel to be 240 m and the length of the spaceship to be 200 m.

The diagram below shows this situation from the perspective of observer **A**.

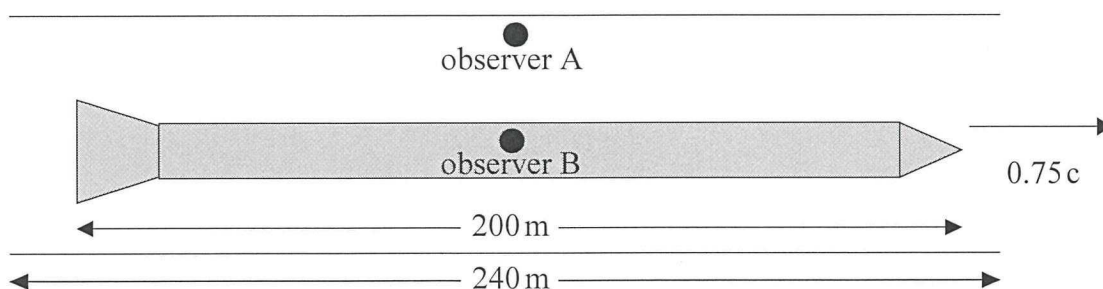

Observer **B**, for whom the spaceship is stationary, is standing at the centre of the spaceship.

c) Calculate the length of the tunnel according to observer **B**.

[2 marks]

Two sources of light are located at each end of the tunnel. The diagram below shows this situation from the perspective of observer **A**.

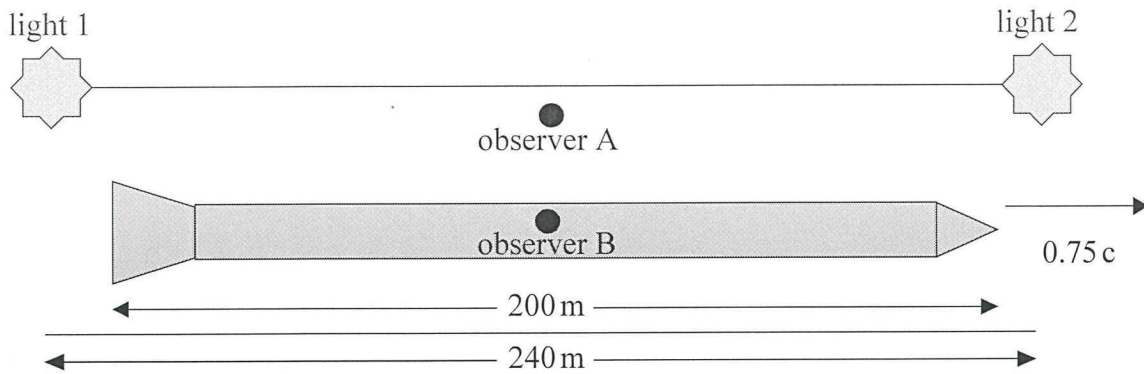

According to observer **A**, at the instant when observer **B** passes observer **A**, the two sources of light emit a flash. Observer **A** sees the two flashes simultaneously.

- d) Discuss whether or not observer **B** sees the two flashes simultaneously. Briefly explain the reasons for your answer.

[2 marks]

Question 8

A car is driving over a hill with a radius of 195 m at a speed of 110 kmh^{-1} . Determine the **magnitude** and **direction** of the reaction force exerted on a 68.5 kg passenger by the seat of the car.

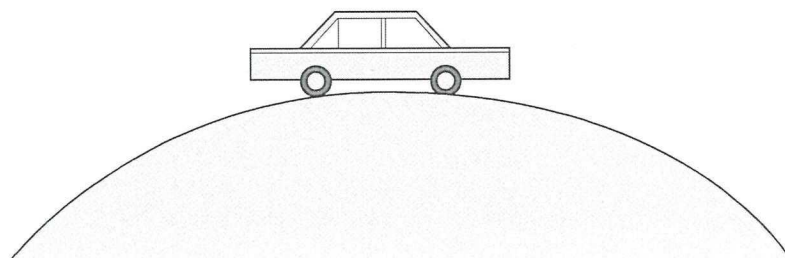

[3 marks]

Question 9

The following tables show information about the properties of quarks and leptons.

Use the information presented in the tables to answer the following questions.

Properties of Quarks

Type of quark	Charge	Baryon number
up u	$+\frac{2}{3}e$	$+\frac{1}{3}$
down d	$-\frac{1}{3}e$	$+\frac{1}{3}$
\bar{u}	$-\frac{2}{3}e$	$-\frac{1}{3}$
\bar{d}	$+\frac{1}{3}e$	$-\frac{1}{3}$

Lepton Numbers

Particle	Lepton number L		
	L_e	L_μ	L_τ
e^-	1		
e^+	-1		
ν_e	1		
$\bar{\nu}_e$	-1		
μ^-		1	
μ^+		-1	
ν_μ		1	
$\bar{\nu}_\mu$		-1	
τ^-			1
τ^+			-1
ν_τ			1
$\bar{\nu}_\tau$			-1

- a) Pions are sub-atomic particles made up of two quarks. Which of the following best describes pions? Circle your answer.

[1 mark]

- A. Leptons
 B. Mesons
 C. Baryons

- b) There are 3 types of pions:

π^+ particles which have a charge of +1 and consist of an up quark and an anti-down quark

π^- particles which have a charge of -1

π^0 particles which have zero charge

State the quark composition of each of the following:

[2 marks]

π^-	π^0
---------	---------

- c) π^+ particles have a mean (average) lifetime of 2.6×10^{-8} seconds in their own frame of reference. In an experiment in a particle accelerator, π^+ particles are accelerated to a velocity of $0.9c$.

Calculate the mean lifetime of these π^+ particles relative to a stationary observer.

[2 marks]

The following table gives some information about particles known as kaons (symbol K).

Particle	Overall charge	Quark Composition
K^-	-1	anti-up, strange
K^+	+1	up, anti-strange
K^0	0	down, anti-strange

- d) Deduce the charge of a “strange” quark.

[1 mark]

- e) Muons are leptons which can decay via the weak force into electrons and neutrinos. One such decay may be represented by the following equation.

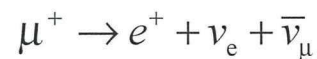

Verify that this decay process conserves **both** charge and lepton number.

[2 marks]

SEE NEXT PAGE

Question 10

A satellite orbits 4.22×10^7 m above the Earth's centre. At a certain point in its orbit around the Earth, the satellite and the Moon line up as shown in the diagram below. Show (with relevant calculations) that in this position the influence of the Moon on the satellite is negligible, compared with the influence of the Earth.

**[4 marks]**

Question 11

A long straight conductor carries a current of 0.60 A from **B** to **A**, as shown in the diagram below.

There is an uncertainty of ± 0.05 A in the current measurement and ± 0.05 m in the distance measurement.

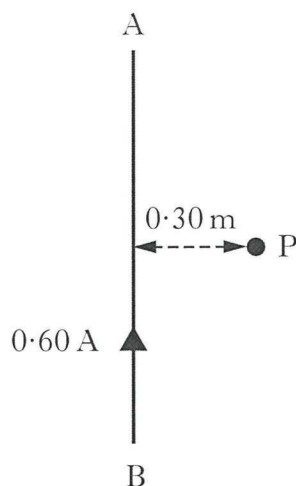

- a) Calculate the strength of the magnetic field at point P, a distance of 0.30 m from the conductor. Include an estimate in the **relative error** for the value the magnetic field strength.

[2 marks]

A second conductor CD, carrying a current of 1.80 A, is placed parallel to AB as shown in the diagram below.

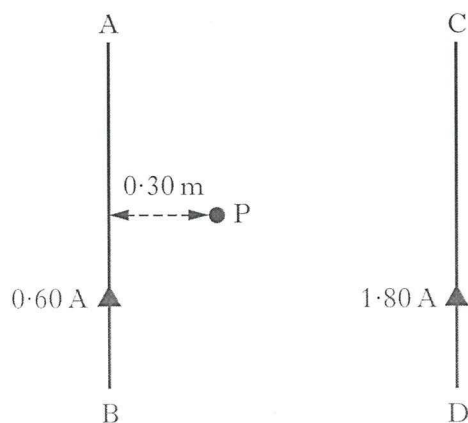

- b) At this separation the resultant magnetic field strength at point P is measured and found to be zero. Explain why the resultant magnetic field strength at point P is zero.

[2 marks]

- c) Calculate the distance of conductor CD to conductor AB.

[2 marks]

SEE NEXT PAGE

Question 12

An “Earth Inductor” consists of a 500 turn coil. It is set up to measure the horizontal component of the Earth’s magnetic field. When the coil is rotated an induced EMF is produced.

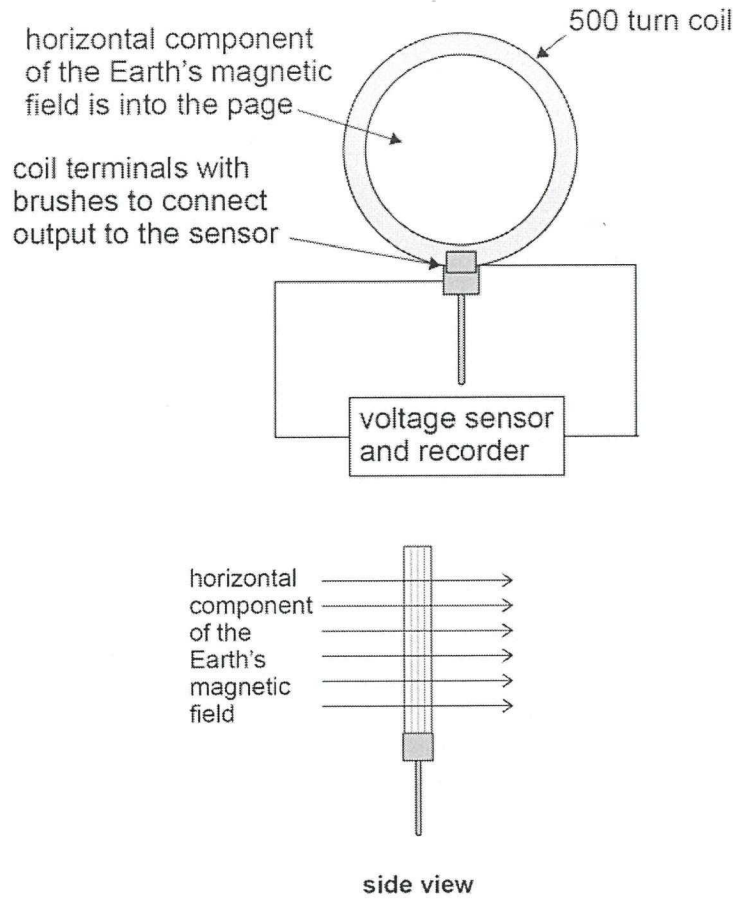

The mean radius of the turns on the coil is 35 cm. The graph below shows how the voltage generated in the coil (V) varies with time when the coil is rotated at 1.5 revolutions per second.

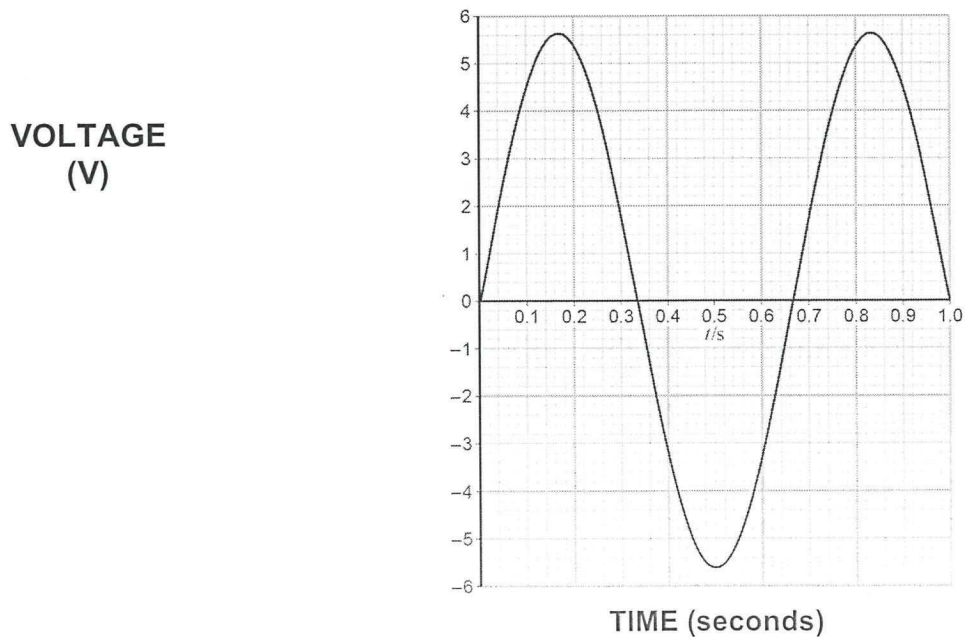

a) What is the **peak voltage** generated in the coil?

[1 mark]

What is the **root mean square (RMS)** voltage generated in the coil?

[1 mark]

b) Determine the strength of the horizontal component of the Earth's magnetic field.

[3 marks]

Question 13

A group of students have set up an experiment similar to that of English physicist Thomas Young. The students' experiment uses microwaves of wavelength $\lambda = 2.8$ cm instead of visible light.

The beam of microwaves passes through two narrow slits S_1 and S_2 as shown in the diagram below. The students measure the intensity of the resulting beam at points along the line shown and determine the positions of maximum intensity. These are shown as filled circles and marked as P_0, P_1, P_2 etc.

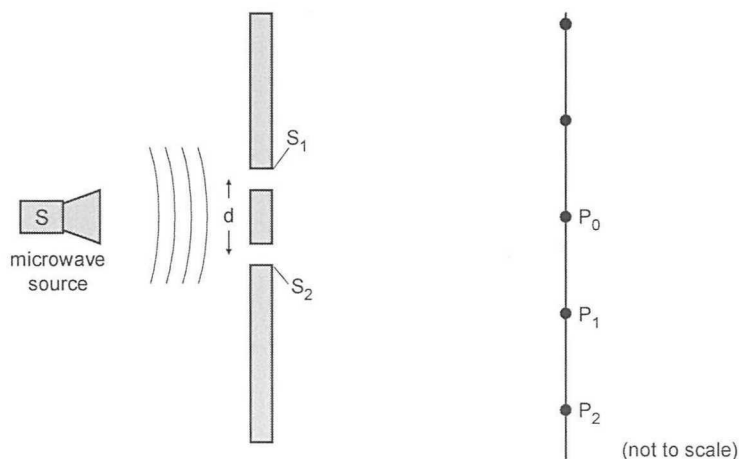

Explain what observations made in Young's Experiment or in the students' experiment tell us about the nature of light.

[3 marks]

Question 14

Two hollow tubes, one made of glass and the other made of aluminium, are positioned vertically. A student holds identical cylindrical magnets against the outsides of the tubes and observes that neither tube attracts a magnet. Based on her observations, the student predicts that each magnet will fall through its respective tube with an acceleration of 9.80 ms^{-2} . The student and her lab partner then drop the magnets into the tubes from rest at position A, as shown below.

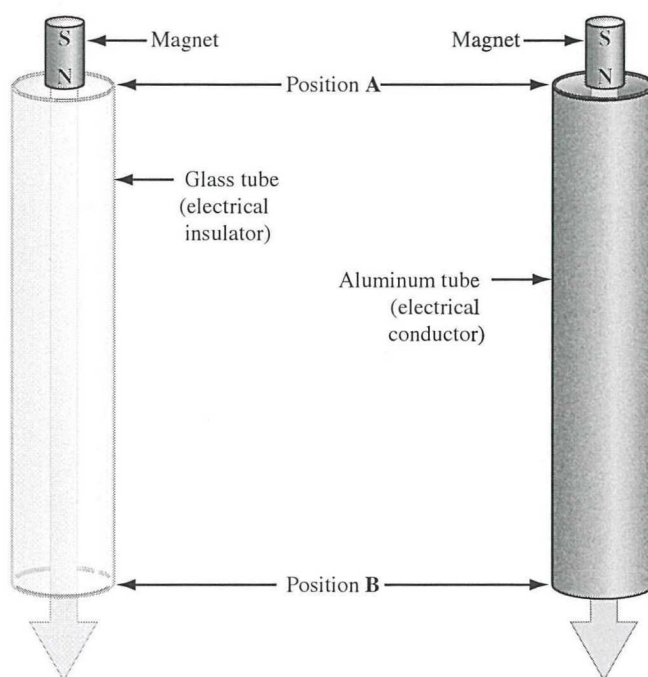

The students make the following observations:

- The magnets do not touch the sides of the tube as they fall.
- The time for the magnet to fall through the aluminium tube is much greater than the time for the identical magnet to fall through the glass tube.

	Glass Tube	Aluminium Tube
Mass of magnet (kg)	0.150	0.150
Tube length (m)	0.95	0.95
Time for magnet to fall from position A to position B	0.44	0.76

SEE NEXT PAGE

SECTION B: (Problem Solving – worth 100 marks or 50 % of total for paper)

Answer all **EIGHT** (8) questions in the spaces provided.

Question 15

An exoplanet is a planet that revolves around a star that is not our sun. As one such exoplanet revolves around a distant star, it causes the star to oscillate, or wobble, in its path as the star and the exoplanet orbit their common centre of mass.

In the following calculations, assume that the centre of the exoplanet's orbit coincides with the star's centre of mass, and that the orbit is circular.

Some details of the star and exoplanet are shown below:

Mass of star $M_S = 2.15 \times 10^{30}$ kg

Mass of exoplanet $M_P = 1.95 \times 10^{27}$ kg

Distance between centre of star and centre of exoplanet = 7.50×10^9 m

- a) Verify that the magnitude of the gravitational force acting on the exoplanet is 4.97×10^{27} N.

[2 marks]

- b) Calculate the exoplanet's orbital velocity. Show **all** workings.

[3 marks]

- c) Calculate the exoplanet's orbital period, and express your answer in hours. Show all workings.

[4 marks]

- d) Calculate the magnitude of the gravitational field strength **due to the star** at the location of the exoplanet.

[2 marks]

- e) What other information is required to determine the acceleration due to gravity on the **surface** of the exoplanet?

[1 mark]

Question 16

Light from the Sun is used to produce a visible spectrum. A student views this spectrum and observes a number of dark lines as shown.

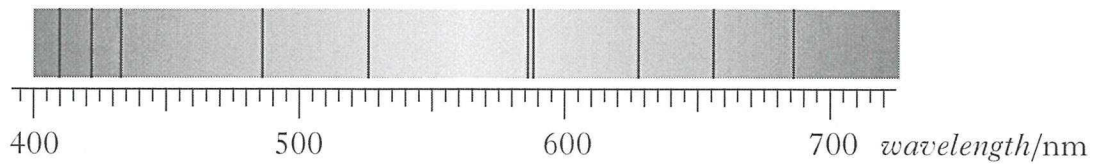

- a) Explain how these dark lines in the spectrum of sunlight are produced.

[3 marks]

- b) Estimate the energy of the photon with the **third longest** wavelength shown in the diagram. Give your answer in eV.

[3 marks]

One of the absorption lines in the spectrum is due to hydrogen. The position of this hydrogen line in the visible spectrum is shown for a distant galaxy, a nearby galaxy and the Sun.

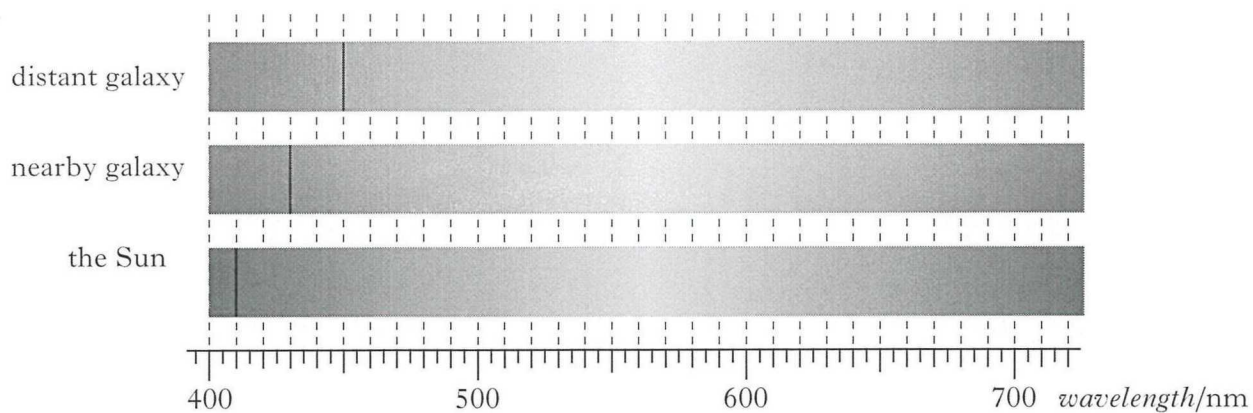

c) Explain why the position of the line is different in each of the spectra.

[3 marks]

d) Explain how the spectra shown above support the theory of the expanding Universe.

[3 marks]

SEE NEXT PAGE

Further analysis of the spectrum of hydrogen shows that the wavelength of a line, as measured in the laboratory, is 656 nm. The same line in the spectrum of light from a distant galaxy is measured to be 790 nm.

- e) Show that the recessional speed of the galaxy is $6.13 \times 10^7 \text{ ms}^{-1}$.

You may use the additional information:

$$v_{\text{galaxy}} = (\Delta\lambda / \lambda) c$$

[2 marks]

- f) The galaxy is 3.1×10^6 light years from Earth. Determine, using your answer to e), a value for the Hubble constant H_0 . Express your answer in units of $\text{ms}^{-1} \text{ ly}^{-1}$

You may use the additional information:

$$v_{\text{galaxy}} = H_0 d$$

[3 marks]

SEE NEXT PAGE

Question 17

An ammeter is a device that is used to determine the magnitude of an electric current. The unknown current is passed through a coil of wire in a magnetic field. The turning effect of the current carrying coil is balanced by a spring and a corresponding value is read from the meter.

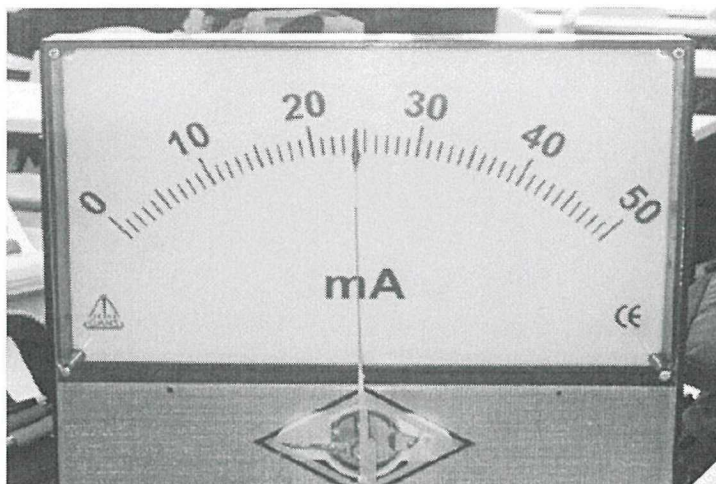

a) Use the photograph of the ammeter scale to determine each of the following:

The value of the current passing through the ammeter in mA.	The absolute uncertainty involved in reading the scale (use the \pm notation)	The relative uncertainty in the current measurement.
---	---	--

[3 marks]

b) A simplified diagram representing one current - carrying wire of the ammeter's coil between two magnets, is shown below. Draw at least **five** field (flux) lines to show the resultant magnetic field between the magnets.

[3 marks]



- c) The actual ammeter shown has 300 turns of wire that form a square coil with sides of 3.20×10^{-2} m. Determine the magnitude of the current in the coil if a torque of 2.65×10^{-2} Nm is produced in the magnetic field of strength 42.5 mT.

[4 marks]

- d) When the ammeter is disconnected, the spring rotates the coil so that the marker needle returns to zero. This causes a change in magnetic flux of 2.18×10^{-5} Wb to occur in the coil in 0.112 seconds. Determine the average potential difference (voltage) induced in the coil during this time.

[3 marks]

Question 18

- a) Ultraviolet light of wavelength 210 nm is shone onto the surface of mercury metal. The work function for mercury is 4.50 eV. Determine the maximum kinetic energy and hence the maximum velocity of the photoelectrons emitted.

[3 marks]

SEE NEXT PAGE

Students conduct three different experiments to investigate the photoelectric effect.

For experiment 1, light of various frequencies is shone on the surface of metal A. The following graph of maximum kinetic energy (KE_{MAX}) of the photoelectrons against frequency was plotted using the data from experiment 1.

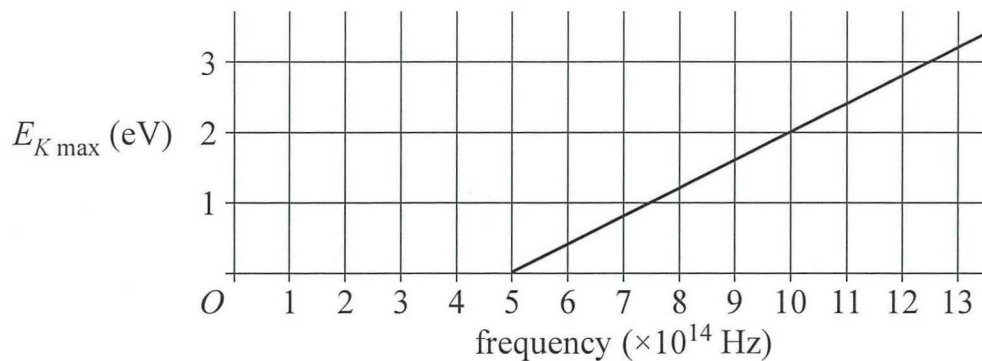

- b) Determine the photoelectric work function (W) for metal A.

[2 marks]

- c) Use the **graph** to calculate the value of Planck's constant for experiment 1.

[3 marks]

SEE NEXT PAGE

In experiment 2, the intensity of the light for each frequency is doubled and again shone on metal A.

The dotted line shows the results of experiment 1.

- d) On the graph below, draw a solid line to sketch the graph of maximum KE against frequency for experiment 2.

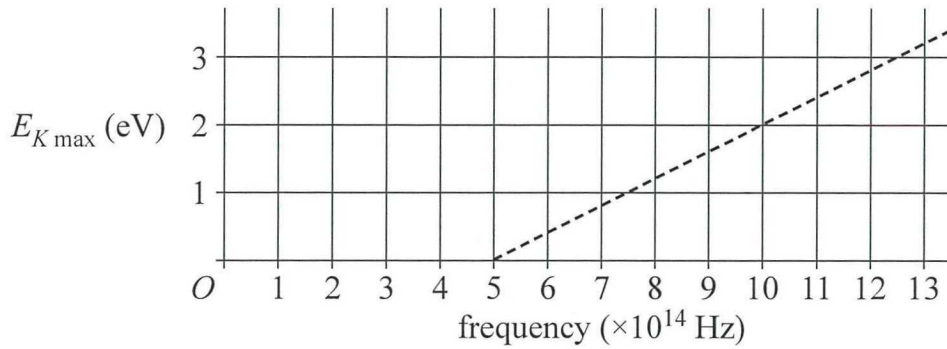

In experiment 3, the metal A is replaced with metal B that has a work function 50% larger than that of metal A. The original intensity of light is used. A dotted line shows the results of experiment 1.

[2 marks]

- e) On the graph below, draw a solid line to sketch the graph of maximum KE versus frequency for experiment 3.

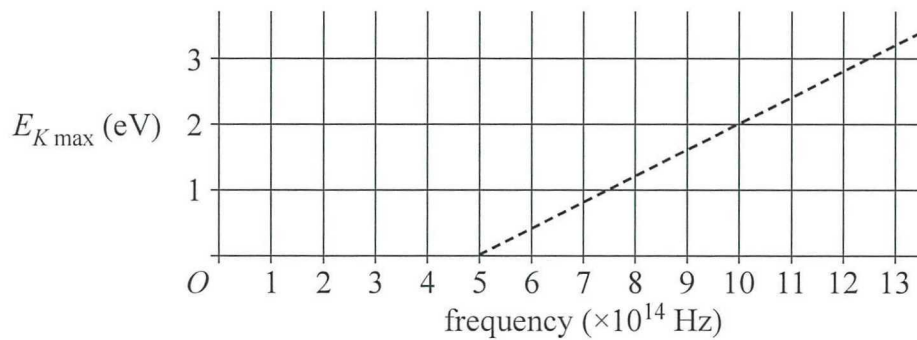

[2 marks]

Question 19

A wind turbine generates electricity at a rate of 200 kW at a voltage of 690 V.

The turbine is connected to a transformer which increases the voltage to 33×10^3 V before connecting it to the electricity grid.

- a) Why is the electricity transmitted in the grid system at such a high voltage?

[2 marks]

- b) The transformer connected to the wind turbine has a primary coil of 75 turns. How many turns does the secondary coil have? Express your answer to the nearest whole number.

[2 marks]

- c) What current flows in the transmission lines which connect the transformer to the grid system?

[3 marks]

- d) If the transmission lines have a resistance of 0.08 ohm per kilometre, how much power is **lost** in the first 40 km of the transmission lines?

[3 marks]

The diagram below shows the construction of a typical transformer.

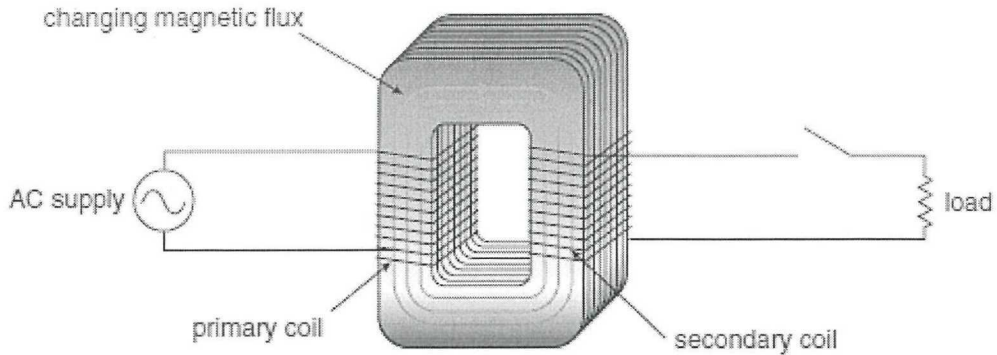

- e) One of the major reasons for transformers to have an efficiency less than 100 % is the formation of Eddy currents within the soft iron core of the transformer.

Why do energy currents form, and why are they undesirable?

[3 marks]

A group of students decide to investigate the principle of a transformer in more detail. They set up the following experiment in which a step-up transformer is connected to a **DC** voltage source.

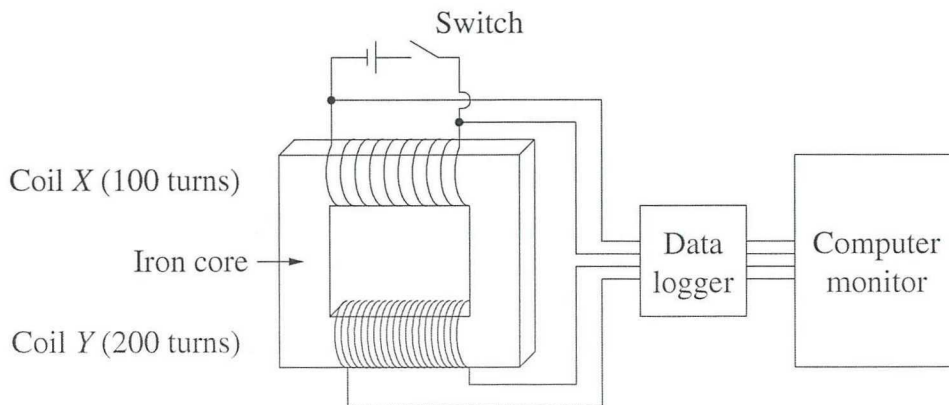

A student closes the switch for a short time, then opens it. The data logger records values of voltage for both coils for the duration of the investigation. The data logger software displays the results as a pair of voltage – time graphs on a computer monitor.

The graphs are shown below.

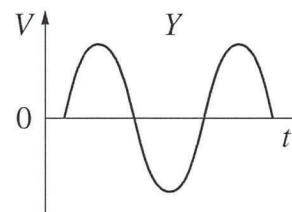
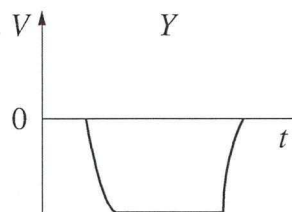
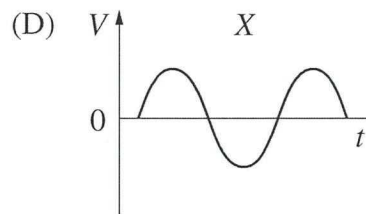
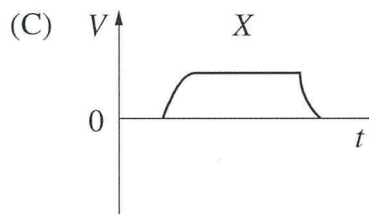
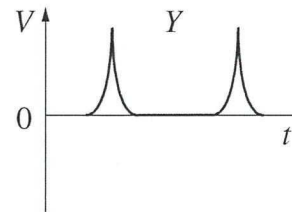
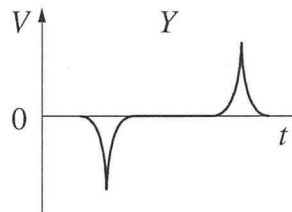
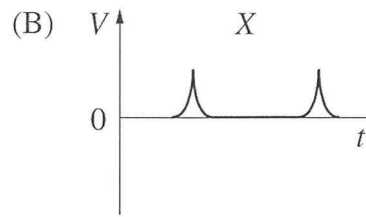
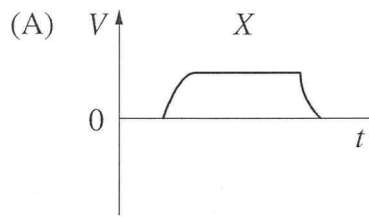

f) Which pair of graphs (A, B, C or D) will correctly represent the voltage for each coil?

Answer = _____

Briefly explain the reason for your answer.

[3 marks]

Question 20

A charge Q_2 is pushed toward a fixed charge Q_1 . A sensor is used to measure the repulsive force being experienced by Q_2 .

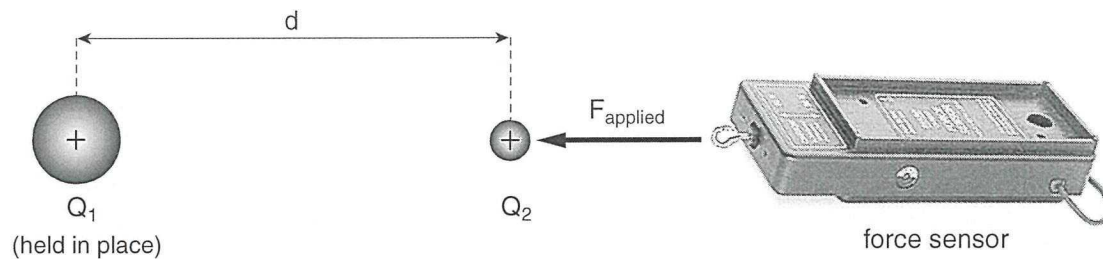

The distance between the charges and the readings on the force sensor are recorded for several different positions. In order to produce a linear plot of the data, the original measurements are adjusted as shown in the table below.

Adjusted Data

FORCE (N)	$\frac{1}{\text{distance}^2} \text{ (m}^{-2}\text{)}$
4.2	25.0
1.8	11.1
1.2	6.2
0.7	4.0
0.4	2.8
0.3	2.0

- a) Construct a linear plot of the adjusted data and determine the gradient of the best fit line. Include the appropriate units. **Use the graph grid on the next page.**

Working for gradient.

[6 marks]

SEE NEXT PAGE

Linear Plot of the Data

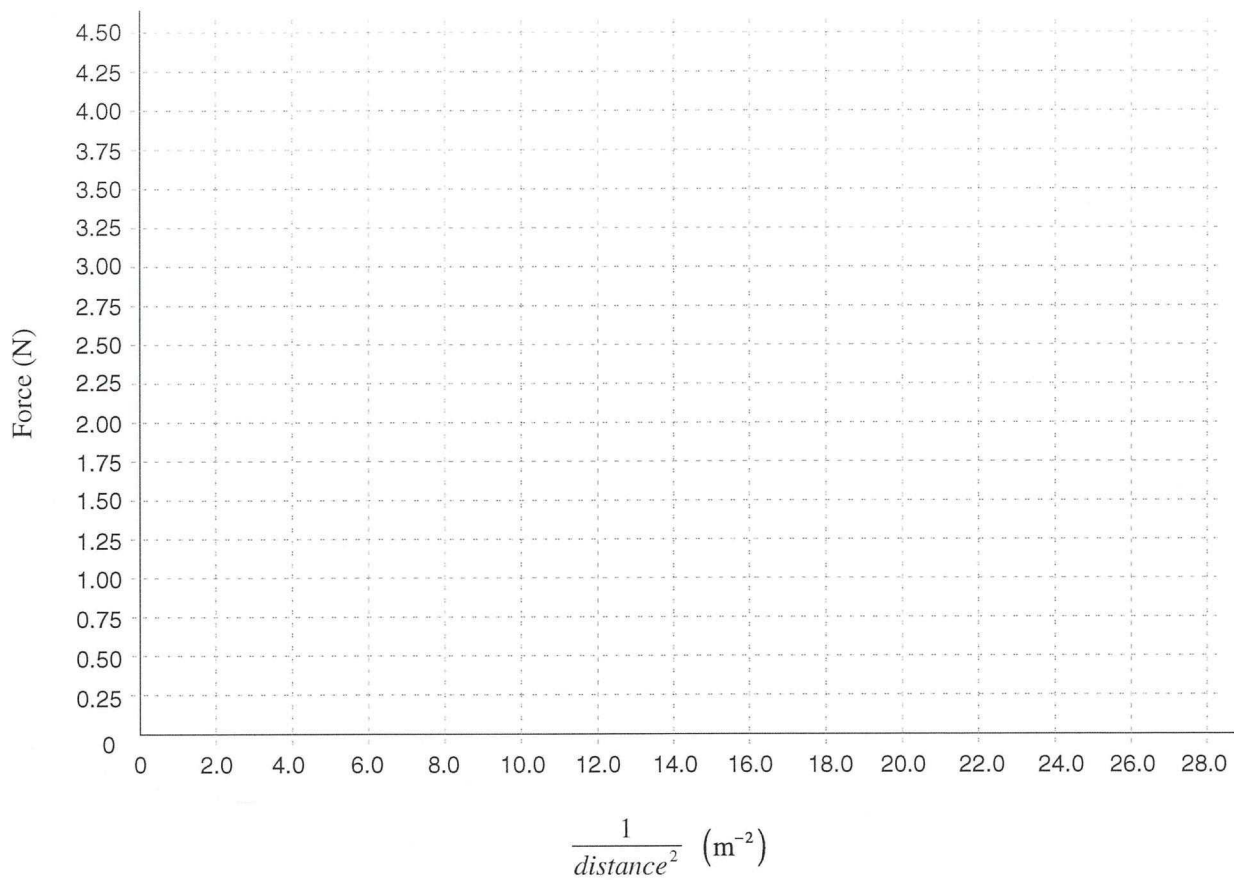

- b) Given that Q_2 has a charge that is three times larger than Q_1 , use the gradient from part a) to calculate the magnitude of charge Q_1 .

[4 marks]

SEE NEXT PAGE

Question 21

It is said that Archimedes used huge levers to sink Roman ships invading the city of Syracuse. A possible system is shown in the following diagram where a rope is hooked on to the front of the ship and the lever is pulled by several men. The mass of the ship is 3.47 tonne.

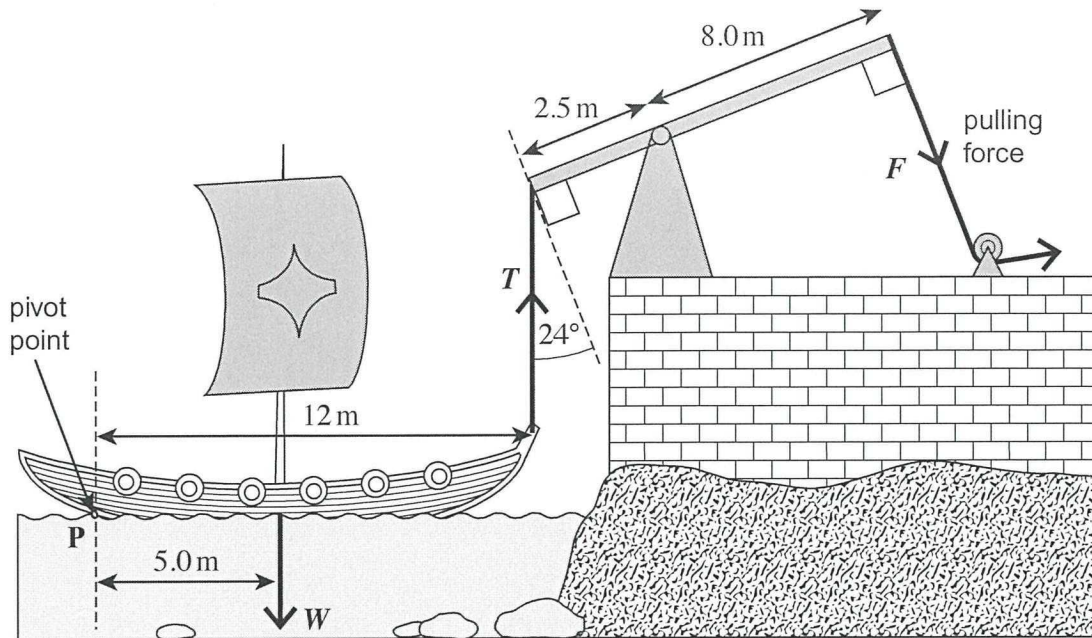

- a) Calculate the minimum vertical force T , required to start to raise the front of the ship. Assume that the ship pivots about point P

[3 marks]

- b) Calculate the minimum force F , that must be exerted to start to raise the front of the ship.

[3 marks]

A 3.00 m long plank with a mass of 10.0 kg is held by a cable at point P, 0.200 m away from the upper end of the plank. The angle between plank and ground is 20.0° and the angle between the plank and the cable is 30.0° .

The ship's cat has a mass of 2.00 kg moves up the plank to Point Q, 2.40 m from the bottom, point O.

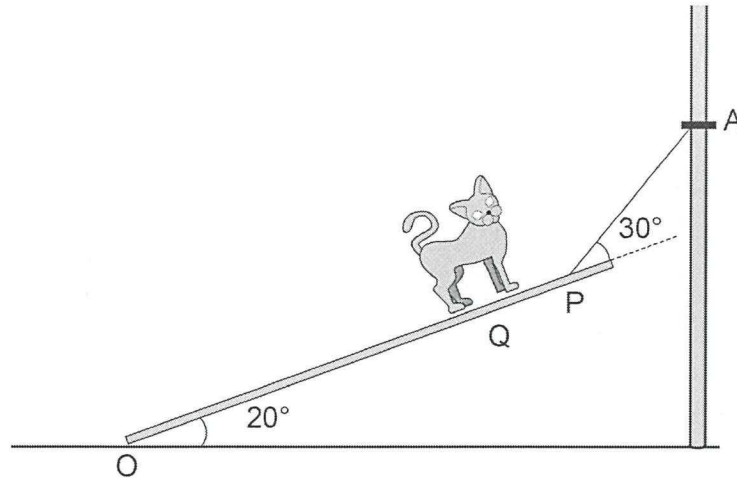

- c) Assuming that Point O is the pivot, calculate the tension force in the cable. Show **all** workings.

[4 marks]

SEE NEXT PAGE

Question 22

Cathode ray tube (CRT) television screens worked by firing a stream of electrons through a vacuum at a phosphor coated screen. The electrons left the cathode and were accelerated by a uniform electric field towards the anode. Some passed through the very small hole at a high velocity. These electrons then travelled at a constant speed toward the screen.

These moving electrons excited the electrons within phosphor atoms on the screen. Each phosphor-electron then emitted green, red or blue light as that phosphor electron decayed back to its ground state.

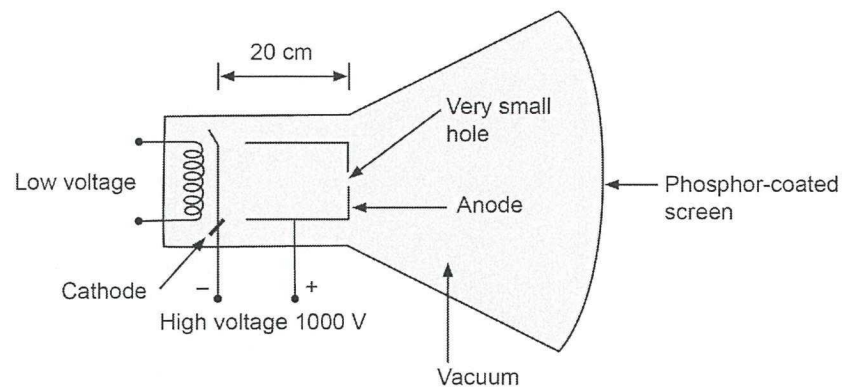

- a) Calculate the magnitude and direction of the electric field between the cathode and anode.

[2 marks]

- b) Calculate the force exerted on each electron as it left the cathode.

[2 marks]

- c) Calculate the kinetic energy of each electron just prior to it colliding with the phosphor atom on the screen.

[3 marks]

- d) These electrons collided with the phosphor screen to produce red light of wavelength 700 nm. Calculate the **difference**, in joules, between energy levels of the phosphor atoms associated with this emission.

[3 marks]

END of SECTION B

SEE NEXT PAGE

SECTION C: (Comprehension and Interpretation – 40 marks or 20 % of total for the paper).

Answer both questions in the spaces provided.

Question 23

A cyclotron is a device used to accelerate charged particles to very high energies. The particles are then used to bombard other particles to investigate the nature of matter. Through experiments involving cyclotrons much of our current understanding of particle physics has been developed.

Sir Charles Gairdner Hospital in Nedlands uses a medical cyclotron to accelerate protons and deuterons to very high energies to produce short-lived radioisotopes for diagnostic purposes.

The structure of a cyclotron can be represented by the following schematic diagram.

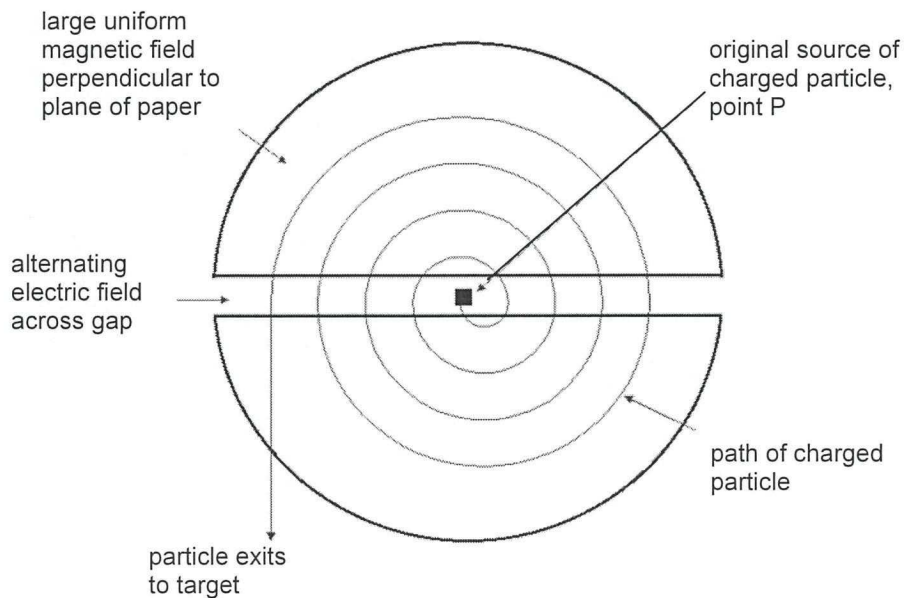

How a cyclotron works

A cyclotron consists of two hollow D-shaped semicircular metal electrodes (called 'dees'), an ion source, an electromagnet and an alternating power supply.

The dees are mounted inside a vacuum chamber that fits between the two flat pole pieces of an electromagnet. The dees are connected to a high frequency alternating voltage supply that provides an alternating electric field across the gap between the dees.

When charged particles are injected at the centre of the dees (point P), they are accelerated by the electric field and then move into a semicircular path inside the hollow space of the dee under the influence of the uniform magnetic field that acts perpendicular to the path of the charged particles. Once inside the dee they are shielded from the electric field and thus do not gain any further energy.

Because the dees are connected to an alternating voltage supply, the charged particles are accelerated by the electric field each time they cross the gap, increasing their energy by a small amount qV . Therefore their speed increases and they move into larger and larger path radii. If the charged particles do not arrive at the gap when the polarity is correct, they will fall out of synchronisation and the beam will be lost. So for the satisfactory operation of the cyclotron, the frequency of the alternating voltage must be equal to the orbital or cyclotron frequency of the charged particles. This condition is valid only when the speed of the charged particles is much less than the speed of light. At higher particle speeds (above about 10% of the speed of light) the frequency of the circulating particle decreases steadily due to relativistic effects. Thus the particle goes out of step with the frequency of the oscillator and its energy stops increasing.

In the normal operation of the cyclotron, when the charged particles reach the outside perimeters of the dees, they are deflected by the electric field of an ejector plate and strike the outside target.

The following table shows some important data about common charged particles.

Charged particle data

Type of charged particle	Mass of charged particle (kg)	Charge of the particle (coulombs)	$\frac{q}{m}$
electron	9.11×10^{-31}	1.60×10^{-19}	
proton	1.67×10^{-27}	1.60×10^{-19}	
deuteron	3.34×10^{-27}	1.60×10^{-19}	

- a) What provides the centripetal force that acts on the charged particle?

[2 marks]

- b) Complete the last column of the data table, giving the ratio to three (3) significant figures.

[3 marks]

- c) The operation of the cyclotron is based on the principle that the frequency of revolution is independent of the speed of the charged particles and the radius of the circular path. Use the formula on the Data and Constants Sheet to show that the frequency f is given by the following equation

$$f = \frac{qB}{2\pi m}$$

[3 marks]

- d) Suppose a cyclotron with a dee radius of 53.0 cm is tuned to accelerate protons at an oscillator frequency of 12.0 MHz. Calculate the strength of the magnetic field needed to accelerate deuterons with the same frequency.

[3 marks]

- e) A conventional cyclotron begins to fail beyond a proton energy of 50 MeV. With the aid of a calculation, explain why this is so.

[3 marks]

An unknown particle was tested and gave the following values of high voltage oscillator frequency and the corresponding magnetic field.

Frequency of high voltage oscillator ($\times 10^6$ Hz)	Magnetic Field B (tesla)
1.0 ± 0.1	0.10 ± 0.05
3.2 ± 0.1	0.42 ± 0.05
6.0 ± 0.1	0.78 ± 0.05
9.0 ± 0.1	1.20 ± 0.05
12.0 ± 0.1	1.62 ± 0.05
15.0 ± 0.1	1.95 ± 0.05

- f) Using the graph paper provided, plot a straight line graph with the frequency on the y-axis and the magnetic field strength on the x-axis. **Show the error bars.**

[4 marks]

- g) Calculate the gradient of this graph. Write the answer to 2 significant figures and include the appropriate units.

[3 marks]

- h) Use the **gradient** to find the ratio of charge on the particle to the mass of the particle.

[3 marks]

- i) Circle the identity of the unknown particle and briefly justify your decision.

*Electron * Proton * Deuteron * Neutron

Justification for answer.

[3 marks]

Question 24**Extreme Ultra-Violet Astronomy**

On June 7, 1992, NASA's Extreme Ultra-violet Explorer (EUVE) satellite was placed in orbit 550 km above the earth. Soaring over the atmosphere, which prevents extreme UV radiation from reaching earthbound telescopes, EUVE has detected a wide variety of astronomical objects. Among them are white dwarfs, coronally active stars and planetary objects in our solar system, all radiating in this high frequency band.

EUVE has even seen 10 sources of extreme UV (EUV) radiation beyond the Milky Way galaxy. This observation was all the more satisfying because of the long standing prediction that interstellar gas would absorb all EUV radiation coming from nearby stars, let alone that from intergalactic objects.

During the 1960's and early 1970's, astronomers believed that UV radiation – having wavelengths between 10 nm and 100 nm – would be completely absorbed by the interstellar medium. Thus, such light, if emanating from any star other than the sun, could not reach the earth's vicinity. If the interstellar medium (thought mainly to be hydrogen and helium) were uniformly distributed throughout the galaxy, EUV astronomy would indeed be impossible.

There are four telescopes on EUVE (see the diagram below). Three of these, the "sky survey" telescopes, point in the same direction and explore the EUV sky in four wavelength bands. The direction in which the survey telescopes look out is perpendicular to the axis of rotation of the EUVE satellite. As the satellite spins, the telescopes scan a strip of the sky; the strip changes daily as the earth travels in its orbit around the sun. The entire sky is mapped in six months. The fourth, "deep survey" telescope is aligned parallel to the axis of rotation of EUVE. The prolonged exposure allows more sensitivity than does the main survey and reveals fainter sources.

- a) What is a typical frequency and photon energy for EUV?

[2 marks]

- b) Why isn't EUV detected by telescopes based on the Earth's surface?

[2 marks]

SEE NEXT PAGE

- c) Look at the photograph of the EUVE satellite. What is the likely purpose of the solar array panels?

[1 marks]

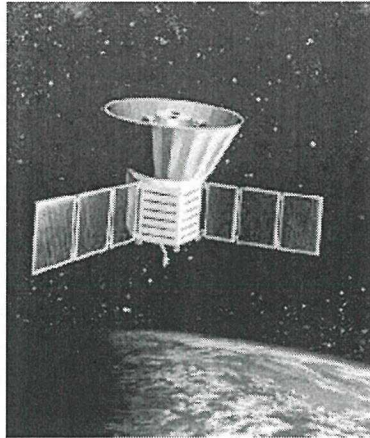

- d) What is the gravitational field strength at the altitude at which the EUVE satellite orbits the Earth?

[3 marks]

- e) Does the EUVE satellite experience a force as it orbits the Earth? Explain.

[2 marks]

- f) Analysis of the EUV radiation from a distant galaxy indicates that the galaxy is approximately 2.70×10^5 light years from Earth. How far from the Earth is the galaxy in kilometres?

[3 marks]

END of QUESTIONS